

Homolytic Reactions of Cubanes. Generation and Characterization of Cubyl and Cubylcarbinyl Radicals

Ernest W. Della,^{*,†} Nicholas J. Head,[†] Philip Mallon,[‡] and John C. Walton^{*,†}

Contribution from the School of Physical Sciences, Flinders University, Bedford Park, South Australia 5042, Australia, and Department of Chemistry, University of St. Andrews, St. Andrews, Fife KY16 9ST, UK. Received April 2, 1992.

Revised Manuscript Received September 21, 1992

Abstract: A series of 4-substituted cubyl radicals was generated by bromine atom abstraction from 1-bromo-4-substituted cubanes. EPR observations showed that the cubyl radicals abstracted secondary hydrogen atoms from the ethyl groups of triethylsilane and decayed mainly by second-order combination reactions. *tert*-Butoxyl radicals abstracted hydrogen atoms from cubane at least 26 times more rapidly than from cyclopropane at $-90\text{ }^{\circ}\text{C}$. Electron-withdrawing substituents on cubane greatly reduced this rate. *tert*-Butoxyl radicals selectively abstracted the cage hydrogens rather than primary methyl hydrogens from methylcubane. Reaction of bromine atoms with cubane occurred at the carbon atoms directly by homolytic substitution, thus initiating a rearrangement sequence which ended when the 7-bromotricyclo[4.2.0.0^{2,5}]oct-3-en-8-yl radical (**28**) rapidly transferred a bromine atom from molecular bromine. By contrast, reaction of cubane with chlorine atoms occurred predominantly via hydrogen abstraction. Cubylcarbinyl radicals were shown by EPR spectroscopy to rearrange with a rate constant $\geq 5 \times 10^9\text{ s}^{-1}$ at $25\text{ }^{\circ}\text{C}$, by a cascade of three β -scissions. The intermediate tricyclo allyl radical **6** was characterized by spectroscopic methods. The first β -scission of the α -hydroxycubylcarbinyl radical occurred at ca. 10^{-3} times the rate for the parent cubylcarbinyl radical, enabling the former radical, and its rearrangement product, to be observed by EPR spectroscopy.

Introduction

Although the cubane skeleton contains ca. 166 kcal mol^{-1} of strain energy (SE),¹ the cubyl radical does not rearrange in solution but retains its integrity under a variety of conditions. Advantage has been taken of this in a number of synthetic applications. The original cubane synthesis² incorporated thermolysis of *tert*-butyl cubaneperoxycarboxylate (**1**) at $150\text{ }^{\circ}\text{C}$ as the final step. Bromo- and iodocubanes were made by homolytic routes,³⁻⁵ including generation of cubyl radicals from *N*-hydroxypyridine-2-thione esters of cubanecarboxylic acids (**2**) in appropriate solvents.⁶ Tin

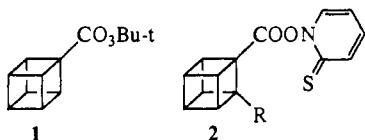

hydride reductions of bromocubanes were employed in the synthesis of cubane and deuteriocubane.^{3,7} Recently, it was found that *tert*-butoxyl radicals abstracted hydrogen atoms from cubane; this process led, via iodo- or chlorocubane, to polyhalogenated cubanes.⁸ Kinetic measurements of the rate of thermolysis of peroxy ester **1** in cumene showed that the rate of cubyl radical formation was only 4.6×10^{-3} relative to the rate of *tert*-butyl radical formation.⁹ The cubyl radical was found to be less selective than acyclic or monocyclic alkyl radicals in halogen abstraction reactions.^{9,10}

β -Scission of the cubyl radical would produce a highly strained bridgehead alkene, and further unravelling of the cube could only occur via additional high-energy intermediates; hence, the cubyl radical prefers intermolecular reactions. Although cubyl radical reactions are extremely fast, we succeeded in observing two cubyl radicals by EPR spectroscopy at low temperatures.¹¹ We report here our EPR spectroscopic study of the reactions of a range of 4-substituted cubyl radicals. The C-H bonds of cyclopropane are strong (ca. 32% s-character), so that hydrogen atom abstraction is difficult. The C-H bond strength of cubane has not been measured, but the C-H bonds contain ca. 30% s-character,⁷ so that the rate of hydrogen atom abstraction from cubane is expected to be of about the same order of magnitude as from cyclopropane. We show that cubane hydrogens are slightly more readily abstracted by *tert*-butoxyl radicals than either cyclopropane hydrogens or the primary hydrogens of the methyl group in methylcubane.

Scheme I

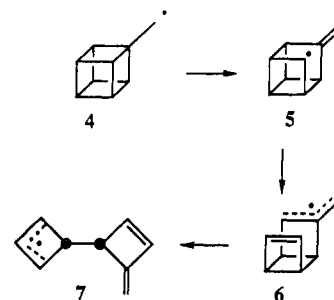

Certain free radicals also *substitute* at tetrahedral carbon atoms, but this S_H2 reaction is usually confined to three-membered rings¹² (eq 1). A few examples of S_H2 reactions of radicals other than halogens including the pseudohalogen bis(trifluoromethyl)aminoxyl¹³ are known, and several types of radicals substitute at the unique quaternary carbon atoms of [1.1.1]propellane.¹⁴ However,

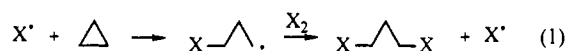

- (1) (a) Kybett, B. D.; Carroll, S.; Natalis, P.; Bonnell, D. W.; Margrave, J. L.; Franklin, J. L. *J. Am. Chem. Soc.* **1966**, *88*, 626-626. (b) Eaton, P. E. *Tetrahedron* **1979**, *35*, 2189-2223. (c) Engler, E. M.; Andose, J. D.; Schleyer, P. v. R. *J. Am. Chem. Soc.* **1973**, *95*, 8005-8025. (d) Wiberg, K. B.; Bader, R. F. W.; Lau, C. D. H. *J. Am. Chem. Soc.* **1987**, *109*, 1001-1012.
- (2) Eaton, P. E.; Cole, T. W., Jr. *J. Am. Chem. Soc.* **1964**, *86*, 3157-3158.
- (3) Della, E. W.; Patney, H. K. *Synthesis* **1976**, 251-252.
- (4) Abeywickrema, R. S.; Della, E. W. *J. Org. Chem.* **1980**, *45*, 4226-4229.
- (5) Moriarty, R. M.; Khosrowshahi, J. S.; Daleki, T. M. *J. Chem. Soc., Chem. Commun.* **1987**, 675-676.
- (6) (a) Eaton, P. E.; Maggini, M. *J. Am. Chem. Soc.* **1988**, *110*, 7230-7232. (b) Della, E. W.; Tsanaksidis, J. *Aust. J. Chem.* **1989**, *42*, 61-69.
- (7) Luh, T.-Y.; Stock, L. M. *J. Am. Chem. Soc.* **1974**, *96*, 3712-3713.
- (8) Reddy, D. S.; Maggini, M.; Tsanaksidis, J.; Eaton, P. E. *Tetrahedron Lett.* **1990**, *31*, 805-806.
- (9) Luh, T.-Y.; Stock, L. M. *J. Org. Chem.* **1978**, *43*, 3271-3273.
- (10) Herwig, K.; Lorenz, P.; Rüchardt, C. *Chem. Ber.* **1975**, *108*, 1421-1436. Giese, B. *Angew. Chem., Int. Ed. Engl.* **1976**, *15*, 173-176.
- (11) Della, E. W.; Eley, G. M.; Head, N. J.; Walton, J. C. *J. Chem. Soc., Chem. Commun.* **1990**, 1589-1591.
- (12) For reviews see: Poutsma, M. A. *Methods Free-Radical Chem.* **1969**, *1*, 79-193. Thaler, W. A. *Methods Free-Radical Chem.* **1969**, *2*, 121-227. Ingold, K. U.; Roberts, B. P. *Free Radical Substitution Reactions*; Wiley-Interscience: New York, 1971. Tedder, J. M.; Walton, J. C. *Adv. Free-Radical Chem.* **1980**, *6*, 155-184.
- (13) Anpo, M.; Chatgililoglu, C.; Ingold, K. U. *J. Org. Chem.* **1983**, *48*, 4104-4106.

[†] Flinders University.

[‡] University of St. Andrews.

free radical halogenation of cyclobutanes usually occurs by straightforward hydrogen abstraction to give unrearranged cyclobutyl derivatives.¹⁵ The only exceptions (excluding fluorinations) are the reactions of halogen atoms at the bridgehead carbon atoms of bicyclo[2.2.0]hexane (**3**)¹⁶ (eq 2) and at the quaternary carbons of [*n*.2.2]propellanes.¹⁷ Bicyclo[3.2.0]heptane did not react in a similar way. It was of special interest therefore to determine whether cubane could undergo S_H2 reactions, and we found that the first step in photobromination was indeed of this type.

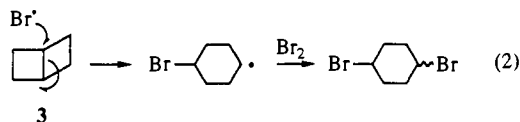

The cubylcarbinyl radical **4** was shown recently^{18a} to rearrange by the mechanism outlined in Scheme I. The initial step was β -scission to give **5**, which sustained a second, rapid β -scission to give the tricyclo allyl radical **6**. A third β -scission, **6** \rightarrow **7**, completed the unravelling of the cube. The last step will be significantly slower because **6** is a resonance-stabilized allyl type radical. The rate constant for ring cleavage of the cyclobutylcarbinyl radical is $4.7 \times 10^3 \text{ s}^{-1}$ at 25 °C,¹⁹ but much greater rate constants are known for species of this class containing additional ring strain. For example, the rate constant for β -scission of the bicyclo[1.1.1]pentylcarbinyl radical (**8**) (eq 3) was found²⁰ to be $1.3 \times 10^7 \text{ s}^{-1}$ at 27 °C. Because of the great relief of ring strain, the

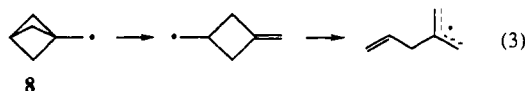

initial β -scission of **4** was expected to be very rapid. Eaton^{18a} and Newcomb^{18b} trapped **4** with selenophenol and derived an extremely high rate constant of ca. $2 \times 10^{10} \text{ s}^{-1}$ at 20 °C. We have examined the rearrangement of **4** by EPR spectroscopy, characterized some of the intermediate radicals, and confirmed the great rapidity of the initial ring cleavage. The archetype cubylcarbinyl radical **4** rearranges too rapidly for EPR detection in solution, but we were able to observe the α -hydroxy derivative.

Results and Discussion

The unknown 4-substituted bromocubanes (**9b–d,g**) were synthesized according to the routes depicted in Scheme II. The following features are noteworthy. For the preparation insertion of fluorine was accomplished by reaction of methyl iodocubane-carboxylate with xenon difluoride²¹ to give **12**, which was transformed into **9b** by hydrolysis followed by application of Barton bromodecarboxylation methodology.^{6b} 4-Phenylcubyl bromide (**9c**) was synthesized from the corresponding iodide **13**, which was available from other work, by halogen–metal exchange and treatment of the derived (4-phenylcubyl)lithium with 1,2-dibromoethane. In the case of the bromide **9d**, it was decided to introduce the methyl group at the bromo ketal stage by converting

(14) Wiberg, K. B.; Waddell, S. T.; Laidig, K. *Tetrahedron Lett.* **1986**, *27*, 1553–1556. Bunz, U.; Polborn, K.; Wagner, H.-U.; Szeimies, G. *Chem. Ber.* **1988**, *121*, 1785–1790.

(15) Nevill, W. A.; Frank, D. S.; Trepka, R. D. *J. Org. Chem.* **1962**, *27*, 422–428. Ashton, D. S.; Tedder, J. M. *J. Chem. Soc., Perkin Trans. 2* **1972**, 965–967. Ashton, D. S.; Singh, H.; Tedder, J. M.; Walton, J. C.; Watt, E. A. *J. Chem. Soc., Perkin Trans. 2* **1973**, 125–128.

(16) Walton, J. C. *J. Chem. Soc., Chem. Commun.* **1987**, 1252–1254. Walton, J. C. *J. Chem. Soc., Perkin Trans. 2* **1988**, 1371–1376.

(17) Eaton, P. E.; Nyi, K. J. *Am. Chem. Soc.* **1971**, *93*, 2786–2788. Eaton, P. E.; Temme, G. H. *J. Am. Chem. Soc.* **1973**, *95*, 7508–7510.

(18) (a) Eaton, P. E.; Yip, Y. C. *J. Am. Chem. Soc.* **1991**, *113*, 7692–7697. (b) Choi, S.-Y.; Eaton, P. E.; Newcomb, M.; Yip, Y. C. *J. Am. Chem. Soc.* **1992**, *114*, 6326–6329.

(19) Beckwith, A. L. J.; Moad, G. J. *Chem. Soc., Perkin Trans. 2* **1980**, 1083–1092. Ingold, K. U.; Maillard, B.; Walton, J. C. *Ibid* **1981**, 970–974. Maillard, B.; Walton, J. C. *Ibid* **1985**, 443–450.

(20) Della, E. W.; Schiesser, C. H.; Taylor, D. K.; Walton, J. C. *J. Chem. Soc., Perkin Trans. 2* **1991**, 1329–1333.

(21) Della, E. W.; Head, N. J. *J. Org. Chem.* **1992**, *57*, 2850–2855.

Table I. EPR Parameters of Cubyl, Substituted Cubyl, and Substituted Cubylcarbinyl Radicals^a

radical	R	<i>a</i> (3 H _{β}) ^b	<i>a</i> (3 H _{γ}) ^c	<i>a</i> (other)	<i>n</i> ^d	
Cubyl Radicals						
10a	H	12.4	8.2	6.3(H _{δ})	0.57 \pm 0.20	
10b	F	10.8	6.2	29.1(F)	0.60 \pm 0.25	
10c	Ph	12.2	7.7			
10e	Br	[12.2] ^e	[8.0] ^e			
10f	CO ₂ Me	12.3	7.8		0.54 \pm 0.05	
10g	Cl	10.9	7.0	4.3(³⁵ Cl)		
radical	R	<i>a</i> (H _{β})	<i>a</i> (H _{γ})	<i>a</i> (H _{δ})	<i>a</i> (CH ₃)	<i>n</i>
Methylcubyl Radicals ^a						
10d	4-Me	12.3 (3 H)	7.9 (3 H)		0.18	0.64 \pm 0.05
25	2-Me	12.4 (2 H)	8.0 (3 H)	6.3	2.4	
26	3-Me	12.4 (3 H)	8.0 (2 H)	6.3	1.85	
radical		<i>a</i> (H _{α})	<i>a</i> (H _{2,6,8})	<i>a</i> (H _{3,5,7})	<i>a</i> (OH)	
Substituted Cubylcarbinyl Radicals ^{a,f}						
36a		14.1	2.80	1.25	1.25	
36b		14.1	2.80	1.25	ϵ	

^aIn cyclopropane solution at –120 °C: hfs in gauss, *g* factors 2.0027 \pm 0.001. ^bH(2,6,8). ^cH(3,5,7). ^dExponent of light intensity. ^eTentative values. ^f*g* factors, 2.003 \pm 0.001. ^gDeuterium hfs unresolved.

14 into the corresponding sulfonate ester **15**, which was to be reduced with lithium aluminum hydride. Under the tosylation conditions, the chloride **16** was obtained instead,²² demonstrating the rapidity with which the intermediate tosylate undergoes S_N2 displacement. Removal of chlorine was effected with sodium borohydride in HMPA, and the product **17** was elaborated to **9d**. Production of methylcubane (**18**) was readily achieved by treatment of lithiocubane with methyl triflate.

Bromine Atom Abstraction from Cubanes; EPR Spectra of Cubyl Radicals. As reported previously,¹¹ cubyl (**10a**) and 4-fluorocubyl radicals (**10b**) were generated from the corresponding bromides (**9a,b**) by bromine atom abstraction with triethylsilyl radicals and observed by EPR spectroscopy at low temperatures [–120 < *T* < –80 °C] in cyclopropane solution. Cubyl radicals with other substituents at C(4) (eq 4) have now been generated and observed by the same method (spectra available as supplementary material).

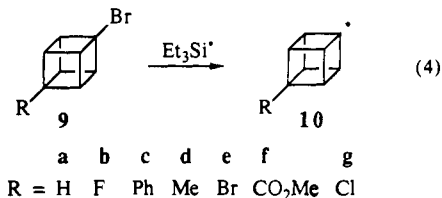

The spectra degraded rather rapidly, except for that of **10f**, and could not be observed at all with tin-centered radicals as the abstracting species. Radicals **10a** and **10b** gave large, well-resolved, hyperfine splittings (hfs) from the substituent at C(4) (δ -position); a small hfs from the ϵ -hydrogens of the CH₃ group of **10d** was visible under high-resolution conditions (Table I). The hfs of the δ -³⁵Cl atom of the 4-chloro radical **10g** was also clearly marked; this is probably the first time that such a long-range chlorine hfs has been resolved. The spectra were not strong enough for the hfs of the ³⁷Cl isotope to be distinguished with certainty. Spectra of the 4-phenyl (**10c**) and 4-bromo radicals (**10e**) were extremely weak, and for the latter only a tentative analysis was possible.

Previously, we assigned the larger quartet hfs to the γ -hydrogens [H(3,5,7)] and the smaller quartet hfs to the β -hydrogens [H(2,6,8)], because semiempirical INDO and AM1 SCF-MO calculations predicted larger spin densities at the γ -hydrogens.¹¹ However, Michl and co-workers have shown that the spectra of deuterium-labeled cubyl radicals implied the reverse assignment,²³

(22) Key, J. Ph.D. Dissertation, University of Hull, Hull, England, 1968.

(23) McKinley, A. J.; Michl, J.; Eaton, P. E.; Zhou, J. P. Unpublished results. We thank Professor J. Michl for communicating this result to us prior to publication.

Scheme II

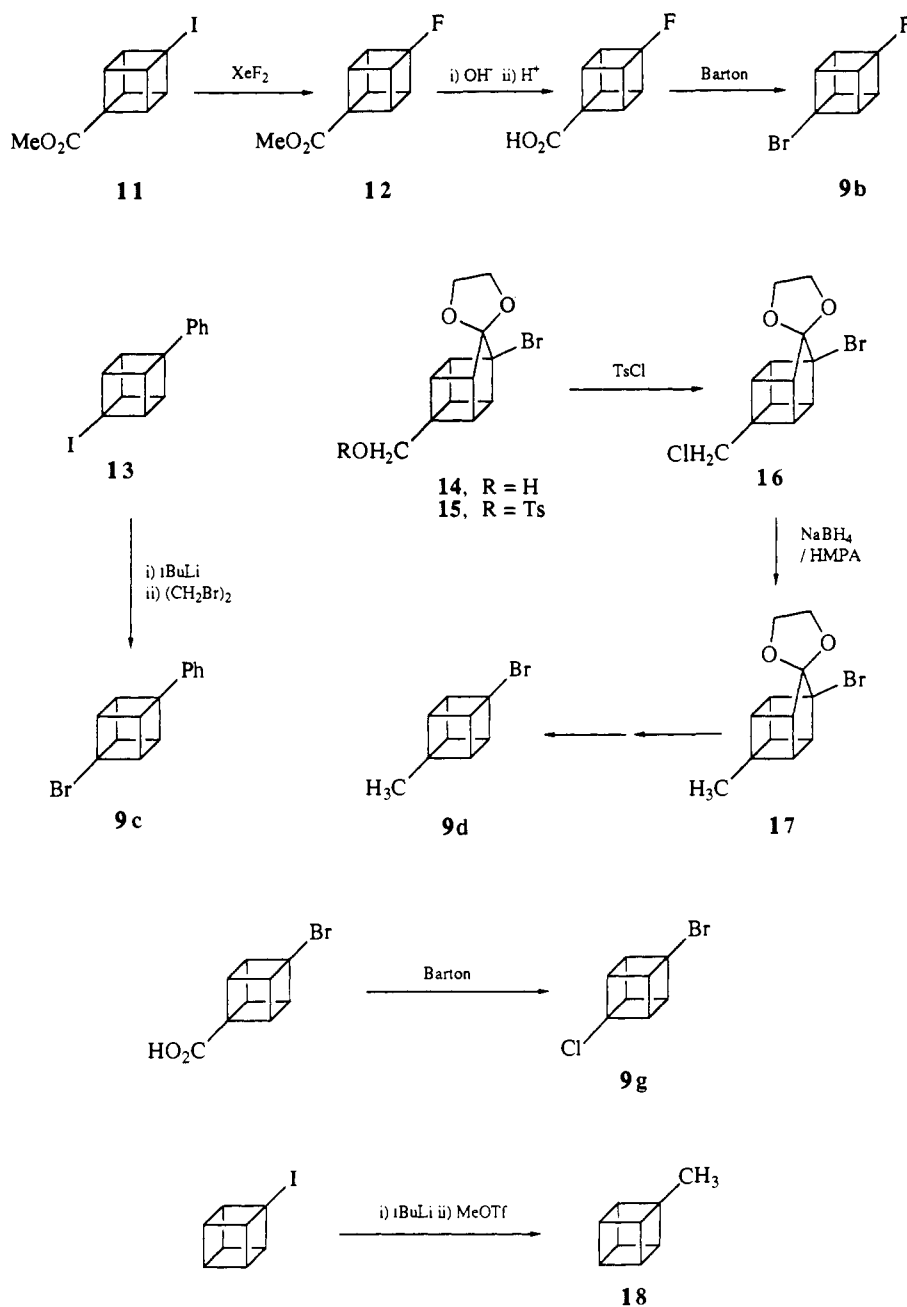

our results with 2-methyl- and 3-methylcubyl radicals are in better agreement with Michl's conclusion (vide infra). The assignments in Table I are based on this updated information. The variations in the magnitude of the H_β and H_γ hfs as the 4-substituent changes are comparatively small, and no simple trend can be discerned. Neither the H_β nor the H_γ hfs correlate with the σ_p , σ_1 , or σ^* parameters of the 4-substituents. Not surprisingly, in view of the inability of the semiempirical SCF-MO methods to correctly order the spin densities at C(2) and C(3), AM1 calculations did not provide an explanation of the hfs variations in terms of computed spin density changes or structural changes as the 4-substituent was varied.²⁴ The small magnitude of the β -hydrogen hfs indicates that, as expected, hyperconjugation is unimportant in cubyl radicals.

The EPR spectrum of each cubyl radical listed in Table I showed the presence of a second radical which was the same in

each case. The second spectrum was eventually analyzed as follows: $a(3 \text{ H}) = 25.5$, $a(1 \text{ H}) = 20.4$, and $a(1 \text{ H}) = 12.0 \text{ G}$ at -120°C ; we attribute it to the 1-(diethylsilyl)ethyl radical (**19**). The concentration of **19** was reduced at lower Et_3SiH concentrations, and this expedient enabled spectra of the cubyl radicals almost free of interference to be obtained. The formation of **19** is surprising because other carbon-centered radicals, including various cyclopropyl radicals,²⁵ selectively abstract the weakly bound SiH to give only the triethylsilyl radical, and in fact **19** has not been spectroscopically detected previously.^{26,27} It appears

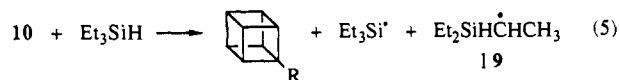

(25) Kawamura, T.; Tsumura, M.; Yokomichi, Y.; Yonezawa, T. *J. Am. Chem. Soc.* **1977**, *99*, 8251-8256.

(26) The $\text{Et}_3\text{Si}^\bullet$ radical is not detected by EPR spectroscopy in the presence of an organic bromide because its stationary concentration is kept below the detection limit by its rapid abstraction of bromine atoms from the organic bromide. $\text{Et}_3\text{Si}^\bullet$ radicals have been observed in the absence of organic bromides (see ref 27).

(24) This is, of course, an extremely severe test of the computational methods, involving as it does, open-shell species containing highly strained four-membered rings and bridgehead C-atoms, and it takes AM1 far beyond the limits of its parametrization.

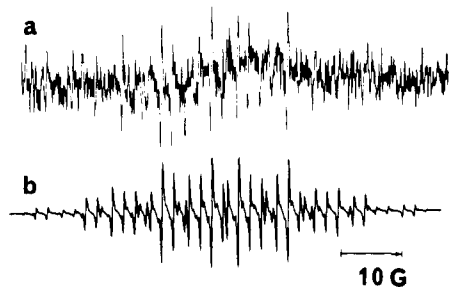
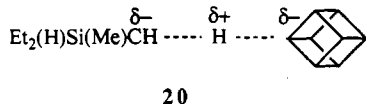

Figure 1. (a) 9.3-GHz EPR spectrum obtained on hydrogen abstraction by *tert*-butoxyl radicals from methylcubane at $-120\text{ }^{\circ}\text{C}$ in cyclopropane solution. (b) Computer simulation of the combined spectrum of radicals **10d**, **25**, and **26** with their concentrations in the ratio 1:3:3 and hfs as in Table I.

that cubyl radicals abstract the secondary hydrogens of the ethyl groups of Et_2SiH in competition with abstraction of the silyl hydrogen (eq 5). R_3Si groups act as electron attractors in free radical reactions,²⁸ and one interpretation of the formation of **19** is that cubyl radicals are strongly nucleophilic, i.e., that the transition state for hydrogen atom abstraction is stabilized by structures such as **20**. Alternatively, the formation of **19** may simply be a manifestation of the high reactivity and low selectivity of cubyl radicals when compared with alkyl radicals.⁹



On shuttering the photolysis beam, the spectrum of each cubyl radical decayed within the spectrometer response time, i.e., the radical lifetimes were $<10^{-3}$ s. For those radicals with sufficiently strong EPR signals, the exponent of the light intensity n was determined by measuring the change in signal height on attenuating the light beam with calibrated gauzes. The accuracy was limited because of the rapid degradation of the spectra, but values of n obtained for four radicals are noted in Table I. The experimental exponents exceed the theoretical value for second-order termination (0.5) only marginally, and we conclude that cubyl radicals decay mainly, if not entirely, by second-order processes. Disproportionation involving two cubyl radicals can probably be ruled out because this would involve formation of the unstable bridgehead cubene **21**^{6a} (Scheme III). Dimerization to give cubylcubanes (**22**) is likely to be the dominant termination, but cross-combination with other radicals to give **23** and cross-disproportionation, e.g., to give **24**, may also contribute. The reaction mixtures were examined by GC-MS. At short photolysis times the main products were *tert*-butyl alcohol and the silane oxidation product $\text{Et}_2\text{SiOSiEt}_3$. The system containing **9d** was monitored periodically, up to 48 h of photolysis when all of the reactant had been consumed. A complex range of products developed, including much intractable tar. The cross-disproportionation product methylcubane (**18**) was identified as a minor component, but we were unable to either confirm or exclude the formation of dimers **22** or cross-combination products **23**.

Hydrogen Atom Abstraction from Cubanes. Cubyl radicals were also generated by hydrogen atom abstraction from cubane by photochemically produced *tert*-butoxyl radicals. When cubane (1.9×10^{-4} mol) was dissolved in cyclopropane (2.9×10^{-3} mol), the measured radical concentration ratio, [cubyl]/[cyclopropyl], was 1.7 at $-90\text{ }^{\circ}\text{C}$. Hence, it follows that $k_{\text{H}}(\text{cubyl})/k_{\text{H}}(\text{c-C}_3\text{H}_6) \geq 26$ (or ≥ 19.5 on statistical correction), where k_{H} is the rate constant for hydrogen abstraction from each hydrocarbon by *tert*-butoxyl radicals:



(27) Krusic, P. J.; Kochi, J. K. *J. Am. Chem. Soc.* **1969**, *91*, 3938–3940. Jackson, R. A. *J. Chem. Soc., Perkin Trans. 2* **1983**, 523–529.

(28) Barker, P. J.; Davies, A. G.; Henriques, R.; Nedelec, J.-Y. *J. Chem. Soc., Perkin Trans. 2* **1982**, 745–750.

Scheme III

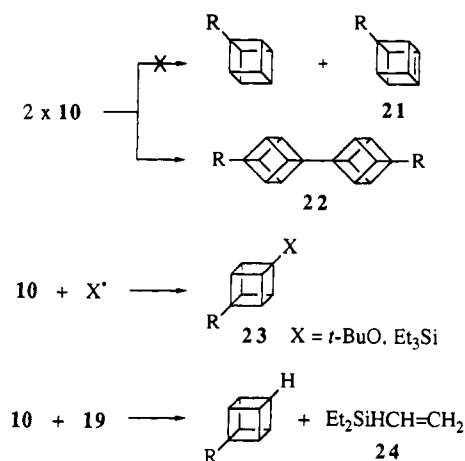

Examination of the EPR tube showed that some cubane had crystallized out at $-90\text{ }^{\circ}\text{C}$, and the result is therefore a lower limit. The higher rate constant for hydrogen atom abstraction from cubane suggests that the C–H bond dissociation energy in cubane might be less than that of cyclopropane ($106.3\text{ kcal mol}^{-1}$).^{29,30}

To compare abstraction of cubyl hydrogen with abstraction of primary hydrogen, methylcubane (**18**) was examined. The EPR spectrum obtained from photolysis of di-*tert*-butyl peroxide and **18** in cyclopropane at $-120\text{ }^{\circ}\text{C}$ is shown in Figure 1a. Neither cyclopropyl radicals nor cubylcarbinyl radicals (nor rearranged species from **4**) were detectable. The 4-methylcubyl radical was easily identified by comparison of this spectrum with that of **10d**. We attribute the other lines to the 2-methyl- (**25**) and 3-methylcubyl radicals (**26**) (eq 7). Simulations with many different

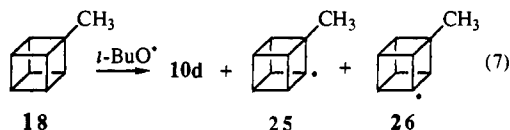

sets of hfs and relative concentrations were made. Best fit (Figure 1b) was achieved with the hfs noted in Table I and radical concentrations in the ratio which would be expected if hydrogen atom abstraction was statistical, i.e., **10d**:**25**:**26** = 1:3:3. Because of the weakness of the spectrum, this fit may not be unique (see supplementary material); however, it is probable that the radical with the largest $a(\text{CH}_3)$ is the 2-methylcubyl (**25**). Consequently, because of the different numbers of β - and γ -hydrogens in **25** and **26**, the 12.4 G hfs should be assigned to the β -hydrogens and the 8.0 G to the γ -hydrogens. This agrees with Michl's work²³ (vide supra).

It is surprising that *tert*-butoxyl radicals abstract cubyl hydrogen atoms in preference to methyl hydrogens. The bond dissociation energy of methyl hydrogens in ethane is³¹ $100.5\text{ kcal mol}^{-1}$, and a value of about this order might be expected³² for the methyl hydrogens of **18**. Ignoring polar, inductive, etc. effects, the experimental observation implies that the cubane C–H bond dissociation energy is less than this. However, such a low value runs counter to expectation. For example, a recent ab initio calculation, with a 6-31G* basis set, predicted that formation of the cubyl

(29) McMillen, D. F.; Golden, D. M. *Annu. Rev. Phys. Chem.* **1982**, *33*, 493–532.

(30) For a recent analysis of the thermochemistry of bridgehead radicals, including cubyl, see: Walton, J. C. *Chem. Soc. Rev.* **1992**, *21*, 105–112.

(31) Seetula, J. A.; Russell, J. J.; Gutman, D. *J. Am. Chem. Soc.* **1990**, *112*, 1347–1353.

(32) Note that $\text{DH}^{\circ}(\text{c-C}_3\text{H}_5\text{CH}_2\text{-H})$ is actually lower than $\text{DH}^{\circ}(\text{primary H})$ by 2–3 kcal mol⁻¹: Bernlöhr, W.; Flamm-ter Meer, M. A.; Kaiser, J. H.; Schmittel, M.; Beckhaus, H.-D.; Rüdhardt, C. *Chem. Ber.* **1986**, *119*, 1911–1918. Walton, J. C. *Magn. Reson. Chem.* **1987**, *25*, 998–1000.

Scheme IV

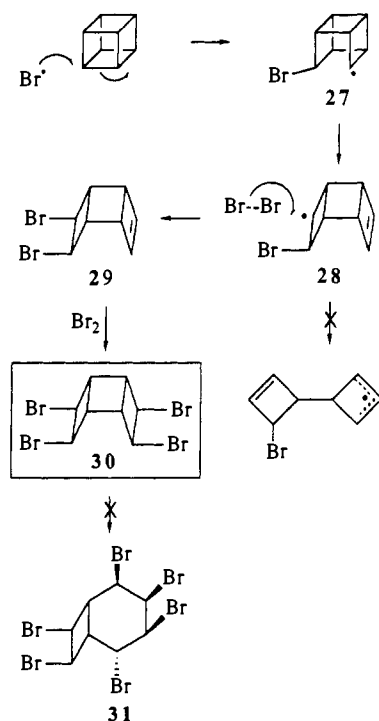

radical from cubane would require 11.0 kcal mol⁻¹ more energy than formation of the *tert*-butyl radical from 2-methylpropane.³³ The experimental value of $DH^\circ(\text{Me}_3\text{C}-\text{H})$ is³¹ 95.9 kcal mol⁻¹ which, on combination with the ab initio result, leads to³⁰ $DH^\circ(\text{cubyl}-\text{H}) = 106.9$ kcal mol⁻¹. This is substantially greater than that suggested by the above straightforward interpretation of the methylcubane result.

The absence of cyclopropyl radicals from Figure 1 shows that $k_{\text{H}}(\text{methylcubane}) > k_{\text{H}}(\text{cubane})$. Hydrogen abstraction by *tert*-butoxyl radicals from substituted cubanes **9d,e** and 1,4-bis-(methoxycarbonyl)cubane was next examined. For all three derivatives cyclopropyl radicals were the only detectable species when cyclopropane was the solvent. With CF₂Cl₂ as solvent, no radicals were detected in the range -130 to -70 °C. Similarly, no interpretable spectra were obtained with neat di-*tert*-butyl peroxide at -40 °C. It appears therefore that electron-withdrawing substituents such as Br and CO₂Me deactivate the cube to hydrogen abstraction, i.e., $k_{\text{H}}(\text{cubyl}-\text{Me}) > k_{\text{H}}(\text{cubane}) > k_{\text{H}}(\text{cubyl}-\text{A})$, where A represents electron-withdrawing substituents. The idea of a simple correspondence between *tert*-butoxyl rate data and C-H bond dissociation energies, toyed with above, is obviously not valid. Further kinetic and thermodynamic studies of cubanes are needed to help rationalize the data.

Homolytic Substitution of Cubane. The best chance of inducing homolytic substitution of cubane appeared to be free radical halogenation analogous to the process employed with three-membered rings and **3**. When molecular bromine (1 or 2 equiv) in degassed CCl₄ was added to a solution of cubane in CCl₄ at 25 °C and illuminated with a tungsten lamp, the bromine color faded and a white solid separated. NMR examination of the remaining CCl₄ solution showed unreacted cubane, particularly when 1 equiv of Br₂ was used, but no bromocubane. The white solid was identified as *cis,cis*-3,4,7,8-tetrabromo-*syn*-tricyclo[4.2.0.0^{2,5}]octane (**30**) from spectral data and a crystal structure (see the Experimental Section). A likely mechanism for its formation is outlined in Scheme IV. Initial S_H2 attack by bromine atoms will induce homolytic cleavage of a cubane C-C bond with formation of radical **27**, which undergoes rapid β-scission to give

the tricyclo radical **28**. The latter is trapped by rapid bromine atom transfer with Br₂ before it can rearrange further. The presence of the *syn* ring structure shields the inner side of **28** so that the Br₂ molecule can only approach *cis* to the existing C-Br bond, and consequently the dibromotricyclooctene **29** is formed stereospecifically with the *cis* arrangement of the two bromine atoms. None of the dibromide **29** was isolated, even when only 1 equiv of Br₂ was used, presumably because it rapidly adds a second bromine molecule, again stereospecifically in the *cis* mode because one side of the double bond is screened by the *syn* cage structure. Formation of one isomer only of the tetrabromo-*syn*-tricyclooctane **30** follows logically, therefore, from the initial S_H2 step. The final *cis* addition of bromine is unusual, but this stereochemistry is by no means forbidden in free radical processes.

Treatment of a solution of cubane in CCl₄ with a saturated solution of chlorine (2 equiv) in CCl₄ at 20 °C led to an instantaneous reaction. There were five major components (total 70%); chlorocubane predominated together with lesser quantities of cubane and a pair of isomeric dichlorocubanes. The remaining products have not been identified, although from GC-MS analysis there is strong evidence for a tetrachloride, possibly **32** (2.3%), among them (see the Experimental Section). The main reaction of the chlorine atoms was therefore hydrogen abstraction.

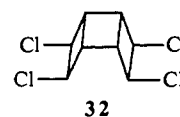

The occurrence of homolytic substitution reactions of cubane can be attributed to the extra strain per C-C bond, i.e., 21 kcal mol⁻¹ per bond compared to 6.5 kcal mol⁻¹ per bond in cyclobutane. The bromination of cubane is a further example of an S_H2 reaction involving four-membered rings. Grouping this with the similar reactions of **3** and [*n.2.2*]propellanes implies that S_H2 reactions are general for compounds with condensed four-membered rings. The tetrabromo product **30** could itself undergo a further substitution reaction to give **31**. Probably this is too slow to observe, firstly because of the insolubility of **30** in CCl₄ and secondly because of the crowded nature of **31** (Scheme IV).

Detection and Rearrangement of Cubylcarbinyl Radicals. On bromine atom abstraction from cubylcarbinyl bromide (**33**) by Et₃Si· a spectrum (see the Supplementary Material), which was unchanged with temperature except for some line broadening, was visible down to -175 °C in *n*-propane. Satisfactory simulation was achieved with the following hfs: $a(1\text{ H}) = 16.4$, $a(1\text{ H}) = 14.2$, $a(2\text{ H}) = 13.7$, $a(1\text{ H}) = 3.0$, $a(1\text{ H}) = 1.3$, and $a(1\text{ H}) = 0.4$ G at -125 °C. These hfs values, assigned to specific hydrogens of the tricyclo allyl radical **6**, are compared with the known hfs³⁴ of the structurally related methylenecyclobutyl radical (**34**) in Scheme V. The similarities are striking, which confirms that **6** is the first detectable intermediate in the rearrangement of **4** in solution. As expected, **6** shows several long-range hfs from

Scheme V

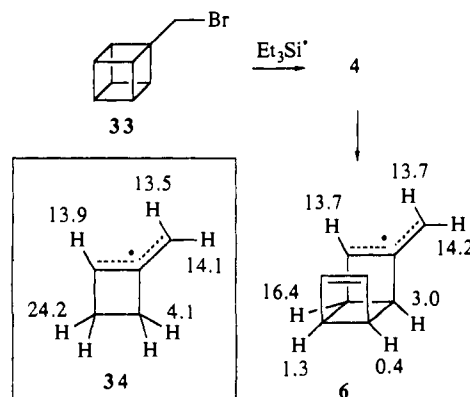

(33) Hrovat, D. A.; Borden, W. T. *J. Am. Chem. Soc.* **1990**, *112*, 3227-3228.

(34) Lunazzi, L.; Placucci, G.; Grossi, L. *J. Chem. Soc., Perkin Trans. 2* **1980**, 1063-1066.

Table II. Rate Parameters and Strain Energy Relief of Cyclobutylcarbinyl Type Rearrangements

radical	k , s ⁻¹ (25 °C)	E_a^a , kcal mol ⁻¹	ΔSE^b , kcal mol ⁻¹	ref
cyclobutylcarbinyl	4.7×10^3	11.7	26.5	19
bicyclo[2.1.1]hexylcarbinyl	1.7×10^5	9.3	31.1	20
bicyclo[1.1.1]pentyl carbinyl (8)	1.3×10^7	7.1	41.1	20
cubylcarbinyl (4)	2×10^{10}	3.7 ^c	83	18
cubylcarbinyl (4)	$\geq 5 \times 10^9$	≤ 4.5	83	this work

^aAll log (A/s^{-1}) values 13 ± 1 . ^bDifference between the SEs of the ring systems in the unrearranged and rearranged radicals. ^cCalculated from the rate constant at 25 °C by assuming log (A/s^{-1}) = 13.0.

distant but favorably placed (all trans with respect to the π -system) hydrogens. The observation of **6** at -175 °C under EPR conditions enables us to estimate that the activation energy for the cubylcarbinyl rearrangement is ≤ 4.5 kcal mol⁻¹. With a normal preexponential factor of 10^{13} s⁻¹, the rearrangement rate constant is $\geq 5 \times 10^9$ s⁻¹ at 25 °C, which is in very reasonable agreement with the value of 2×10^{10} s⁻¹ at 25 °C determined by Eaton and Yip,¹⁸ and confirms that this is one of the fastest known β -scissions in solution.

The first β -scission of **4** will produce radical **5** (Scheme I). It is likely, however, that β -scission of **5** will actually be faster than β -scission of **4**, because in **5** the bond to be broken is in a fixed conformation having optimum overlap with the semiooccupied orbital at the radical center. In addition, β -scission of **5** gives the resonance-stabilized allyl radical **6**. It is not surprising therefore that **5** cannot be observed in this case (or for the α -hydroxy-substituted radical; vide infra). The extremely high rate of rearrangement of **4** was not unexpected. Relief of ring strain plays an important part in β -scission reactions. In the rearrangement of **4** with an SE of 166 kcal mol⁻¹ to **6** with an SE of ca. 83 kcal mol⁻¹, there is an enormous release of strain ($\Delta SE = 83$ kcal mol⁻¹). The rate constants and activation parameters of four leading types of cyclobutylcarbinyl rearrangements are compared in Table II. The rate constants increase monotonically as the relief of strain, ΔSE , increases and the cubylcarbinyl radical result falls in line with the others.³⁵

On warming the EPR sample the spectrum weakened rapidly, so that further rearrangements could not be followed spectroscopically. At -20 °C a set of four central lines, in what was evidently a new radical, was visible, but the signal to noise ratio was too poor for observation of the complete spectrum. These four lines had the same spacing as the four central lines of the substituted cyclobutenyl radical derived from rearrangement of cubylcarbinol (**35**) (vide infra), and we attribute them to radical **7** (Scheme I).

The rate of β -scission of cyclopropylcarbinyl radicals decreased by about a factor of 10 on the introduction of a silyl ether or a similar oxygen functionality, RO, at the radical center.³⁶ To determine whether the rate of cubylcarbinyl β -scission would respond in a similar way, hence enabling us to spectroscopically observe this type of radical, we used cubylcarbinol (**35**) as the radical precursor. The spectrum shown in Figure 2a was obtained on hydrogen abstraction from **35** by *tert*-butoxyl radicals at -120 °C. This was satisfactorily simulated (Figure 2b) with the hfs shown in Table I. We attribute this spectrum to the α -hydroxycubylcarbinyl radical (**36a**). The 14.1 G doublet hfs is of appropriate magnitude for the H_α of an α -hydroxy, C-centered radical, and the spectrum shows two sets of quartet hfs from the two sets of three equivalent cubyl hydrogens as well as a small doublet hfs from the OH hydrogen. Confirmatory evidence was obtained by examination of the deuterium-substituted precursor **35b** made by shaking **35a** with D₂O. The spectrum from **35b** was well-simulated with a similar set of hfs minus the small doublet

(35) The parameters for the cyclopropyl to 2-butenyl rearrangement do not fall on the same curve because the ground and transition state MOs and their energies are very different in this case.

(36) Nonhebel, D. C.; Suckling, C. J.; Walton, J. C. *Tetrahedron Lett.* **1982**, 23, 4477-4480.

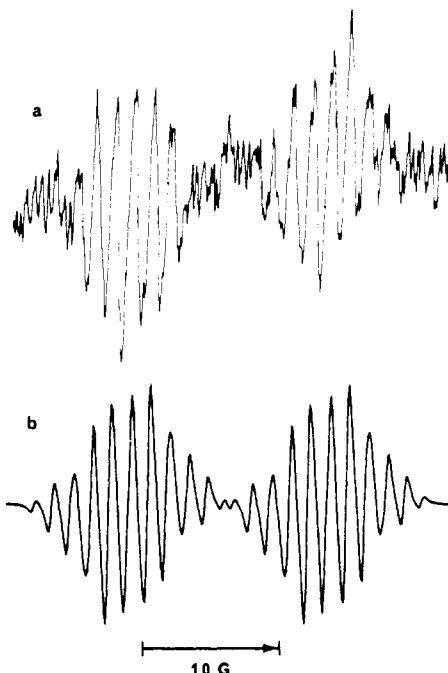
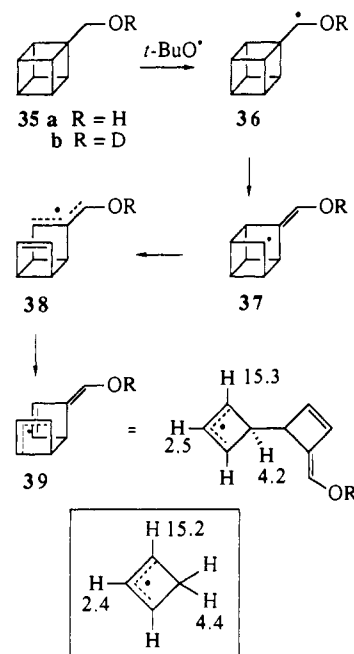

Figure 2. EPR spectrum (9.3 GHz) of α -hydroxycubylcarbinyl radical **36a** obtained on hydrogen abstraction from cubylcarbinol (**35**) in cyclopropane at -115 °C.

Scheme VI



hfs from the OH hydrogen³⁷ (Table I). For **35**, unlike **18**, *tert*-butoxyl radicals selectively abstract from the CH₂OR group rather than from the cube, because the adjacent OR group activates the exocyclic methylene hydrogens.

For both **36a** and **36b**, the spectral intensity diminished quickly and the pattern became more complex on warming above -115 °C, probably because of the formation of **38** (Scheme VI). At -65 °C a single radical was again observed, but the spectral amplitude was extremely weak, and aesthetically pleasing spectra could not be obtained (Figure 3). the protio and deuterio precursors gave essentially the same spectra (Figure 3a,c), which

(37) The triplet hfs from the D nucleus will be ca. one-sixth that of hydroxyl H, i.e., $a(D) = 0.2$ G, which is within the spectral line width of 0.4 G and hence was not resolved.

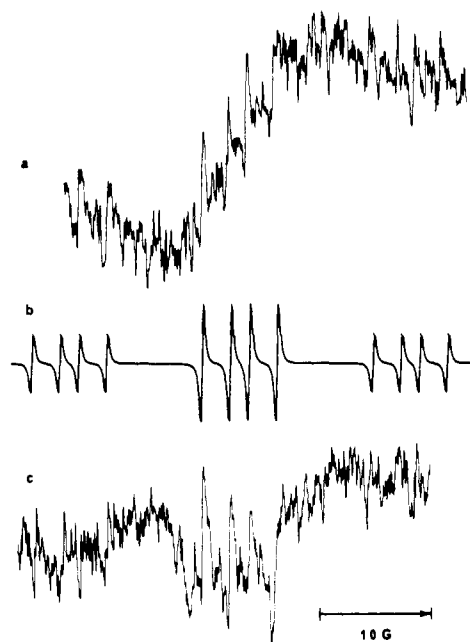
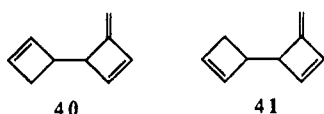

Figure 3. (a) 9.3-GHz EPR spectrum of cyclobutenyl radical **39a** at -65 °C in cyclopropane. (b) Computer simulation; see text. (c) 9.3-GHz EPR spectrum of deuteriated cyclobutenyl radical **39b** at -65 °C in cyclopropane.

consisted of a triplet of double doublets (Figure 3b) [$a(2\text{H}) = 15.3$, $a(1\text{H}) = 4.2$, $a(1\text{H}) = 2.5$ G at -65 °C]. These hfs are very similar to those of the cyclobutenyl radical³⁸ (Scheme VI), so that the spectra can be assigned to the substituted cyclobutenyl radicals (**39a,b**). This is entirely consistent with the finding of Eaton and Yip, who identified trienes **40** and **41** as the products from the tri-*n*-butyltin hydride reduction of cubylcarbiny bromide.¹⁸ Three of the intermediates in the rearrangement sequence of cubylcarbiny radicals have therefore been characterized by EPR spectroscopy, which strongly supports the proposed mechanism (Schemes I and VI).



The spectra from **36** were too weak and too complex for accurate measurement of the rearrangement rate constant by kinetic EPR. However, the activation energy of the **36** → **38** rearrangement was estimated to be 7.5 ± 1.0 kcal mol⁻¹ from the temperature at which the unrearranged and rearranged radicals were equal in concentration,³⁹ i.e., ca. -105 °C. With a normal *A* factor of 10^{13} s⁻¹, the rate constant is 3×10^7 s⁻¹ at 25 °C. The final β -scission, **38** → **39**, was not clearly distinguished on the EPR spectra. However, the formation of **39** was complete by -65 °C, which indicates that the activation energy for this step is ≤ 9.5 kcal mol⁻¹. Therefore, the presence of the α -hydroxy group in the cubylcarbiny radical reduces the rate of the first β -scission by a factor of nearly 10^3 , but the overall rate to the final product of the cascade is about the same as for the parent radical.

Conclusions

We have shown that 4-substituted cubyl radicals are readily generated from 1-bromo-4-substituted cubanes by bromine atom abstraction with $\text{Et}_3\text{Si}^\bullet$ radicals. Under EPR conditions, cubyl radicals decay mainly by bimolecular combination or cross-disproportionation reactions, and they abstract the methylene hydrogen atoms from Et_3SiH . For hydrogen atom abstraction from

cubanes by *tert*-butoxyl radicals, we find $k_{\text{H}}(\text{cubyl-Me}) > k_{\text{H}}(\text{cubane}) > k_{\text{H}}(\text{cubyl-A})$; the cubyl hydrogen atoms of methylcubane are abstracted in preference to the CH_3 hydrogens. Bromine atoms, on the other hand, do not abstract cubyl hydrogens, but directly substitute at a cubyl carbon atom, thus initiating a sequence of rearrangements which is terminated by rapid bromine atom transfer to the tricyclo[4.2.0.0^{2,5}]oct-3-enyl radical (**28**). By contrast, chlorine atoms react with cubane mainly by abstraction of hydrogen. The rearrangement of cubylcarbiny and α -hydroxycubylcarbiny radicals was shown to occur by a cascade of three β -scissions, and three of the reactive intermediates were spectroscopically characterized. The extremely rapid rate of the first β -scission of the parent radical was confirmed, and it was shown that the α -hydroxy substituent decreases this rate by ca. 3 orders of magnitude.

Experimental Section

Routine ¹H NMR spectra were obtained on a Hitachi RS-1200 spectrometer. ¹³C and some ¹H NMR data were collected on a JEOL FX90Q instrument. NMR measurements were made in CDCl_3 solution unless otherwise stated, and chemical shifts relative to TMS are reported in ppm (δ). Mass spectra and high-resolution mass spectra (HRMS) were recorded on a Kratos M25RF spectrometer. EPR spectra were recorded with a Bruker ER 200D spectrometer operating with 100-kHz modulation. Samples were prepared in Spectrosil tubes, degassed, and photolyzed in the cavity by light from a 500-W superpressure Hg lamp. Analytical GC was performed on a Perkin-Elmer 8410 chromatograph using an Alltech Associates RSL-300 (0.53 mm \times 30 m) fused silica column. Elemental analyses were carried out by the Australian Micro-analytical Service. Cubanecarboxylic acid,^{2,40} hydroxymethylcubane,⁴¹ 4-(methoxycarbonyl)cubanecarboxylic acid,^{6b} methyl 4-fluorocubanecarboxylate,²¹ 1-bromo-4-(chloromethyl)pentacyclo[4.2.1.0^{2,5}.0^{3,8}.0^{4,7}]-nonan-9-one ethylene ketal,²² and iodocubane²¹ were prepared according to the designated literature procedures. Bromocubane and 1,4-dibromocubane were prepared as described,^{6b} except that 2-bromo-2-chloro-1,1,1-trifluoroethane was employed as the solvent and bromine atom donor.

4-Fluorocubyl Bromide (9b). A solution of sodium hydroxide (0.12g, 3.0 mmol) in methanol (5 mL) was added to a solution of methyl 4-fluorocubanecarboxylate (0.21 g, 1.2 mmol) in THF (5 mL). The mixture was stirred overnight and then evaporated to dryness. Water (15 mL) was added to the residue, which was then extracted with ether (20 mL). The organic layer was discarded, and the aqueous fraction was acidified to pH 1 with concentrated HCl before being extracted with ether (3 \times 20 mL). The combined ethereal extracts were dried (MgSO_4) and evaporated giving 4-fluorocubanecarboxylic acid (0.19 g, 98%), which was converted into the corresponding bromide under the conditions for bromodecarboxylation employed for the synthesis of the parent bromide above.^{6b} Sublimation (100 °C (3 mmHg)) of the product yielded 4-fluorocubyl bromide (**9b**) (0.17 g, 75%); mp 87 °C; ¹H NMR δ 3.75–4.45 (m); ¹³C NMR δ 103.99 (d, $J = 324.7$ Hz, Cl), 64.99 (d, $J = 24.4$ Hz, C4), 54.02 (d, $J = 25.7$ Hz, C2,6,8), 49.20 (d, $J = 5.8$ Hz, C3). Anal. Calcd for $\text{C}_8\text{H}_6\text{BrF}$: C, 47.8; H, 3.0. Found: C, 47.8; H, 2.9.

4-Phenylcubanecarboxylic Acid. 4-(Methoxycarbonyl)cubanecarboxylic acid in degassed benzene was treated with lead tetraacetate as described,⁴² except that the reaction mixture was irradiated (3 h) with a 300-W tungsten lamp. Purification of the product by column chromatography (elution with 5% EtOAc/hexane) furnished methyl 4-phenylcubanecarboxylate (71%); mp 79–81 °C (lit.⁴² mp 80–81 °C). Hydrolysis of the ester (0.70 g, 2.9 mmol) was accomplished under conditions specified above. Sublimation of the product produced 4-phenylcubanecarboxylic acid (0.43 g, 87%); mp 181 °C; ¹H NMR δ 4.28 (bs, 6 H), 4.75 (bs, 1 H exch), 7.25 (bs, 5 H); ¹³C NMR δ 178.78 (CO), 141.88 (C_{pso}), 128.45 (C_o or C_m), 126.17 (C_p), 124.7 (C_m or C_o), 60.30 (C1), 56.23 (C4), 48.76 (C2,6,8), 46.05 (C3,5,7). Anal. Calcd for $\text{C}_{16}\text{H}_{12}\text{O}_2$: C, 80.3; H, 5.4. Found: C, 80.2; H, 5.5.

4-Phenylcubyl Iodide (13). A mixture of 4-phenylcubanecarboxylic acid (0.40 g) and thionyl chloride (10 mL) was heated under reflux for 2 h. Excess thionyl chloride was removed by distillation (final traces by vacuum), and the 4-phenylcubanecarboxylic acid chloride was dissolved

(40) Chapman, N. B.; Key, J. M.; Toyne, K. J. *J. Org. Chem.* **1970**, *35*, 3860–3867.

(41) Cole, T. W., Jr. Ph.D. Dissertation, University of Chicago, Chicago, IL, 1966.

(42) Moriarty, R. M.; Khosrowshahi, J. S.; Miller, R. S.; Flippen-Anderson, J.; Gilardi, R. *J. Am. Chem. Soc.* **1989**, *111*, 8943–8944.

(38) Krusic, P. J.; Jesson, J. P.; Kochi, J. K. *J. Am. Chem. Soc.* **1969**, *91*, 4566–4568.

(39) Griller, D.; Ingold, K. U. *Acc. Chem. Res.* **1980**, *13*, 317–323.

in benzene (5 mL) and added dropwise to a stirred, boiling, irradiated (300-W tungsten lamp) suspension of the sodium salt of *N*-hydroxypyridine-2-thione (0.29 g, 1.1 equiv), 4-(dimethylamino)pyridine (several milligrams) and 1,1,1-trifluoro-2-iodoethane (0.9 mL, 5 equiv) in benzene (20 mL). After 40 min the mixture was cooled and worked up in the standard manner.^{6b} Sublimation of the residue (130 °C (0.1 mmHg)) gave 4-phenylcubyl iodide (**13**) (0.43 g, 76%); mp 84 °C; ¹H NMR δ 4.29 (s, 6 H), 7.05–7.39 (m, 5 H); ¹³C NMR δ 141.56 (C_{ipso}), 128.61 (C_o or C_m), 126.39 (C_p), 124.87 (C_m or C_o), 60.62 (C₄), 54.39 (C_{2,6,8}), 52.11 (C_{3,5,7}), 39.06 (C₁). Anal. Calcd for C₁₄H₁₁I: C, 54.9; H, 3.6. Found: C, 54.7; H, 3.7.

4-Phenylcubyl Bromide (9c). To a solution of the iodide **13** (0.34 g, 1.1 mmol) in pentane/ether (3:2, 15 mL) at –80 °C was added dropwise a 1.7 M solution of *tert*-butyllithium (in pentane, 1.6 mL, 2.78 mmol). The mixture was held at –80 °C for 10 min and then quenched with excess 1,2-dibromoethane (0.5 mL), after which the cold bath was removed and the solution allowed to warm to room temperature. The mixture was washed with saturated solutions of NH₄Cl (2 × 20 mL) and NaCl (1 × 20 mL) before being dried and concentrated. Excess dibromoethane was removed under vacuum (1.0 mmHg) at ambient temperature, and the residue was distilled (Kugelrohr) (95–120 °C (0.1 mmHg)) to afford 4-phenylcubyl bromide (**9c**) (0.22 g, 75%); mp 68–69 °C; ¹H NMR δ 4.23 (s, 6 H), 7.1–7.4 (m, 5 H); ¹³C NMR δ 141.44 (C_{ipso}), 128.44 (C_o or C_m), 126.27 (C_p), 124.70 (C_o or C_m), 65.11 (C₁), 60.62 (C₄), 53.79 (C_{2,6,8}), 49.29 (C_{3,5,7}). Anal. Calcd for C₁₄H₁₁Br: C, 64.9; H, 4.3. Found: C, 64.9; H, 4.3.

4-Methylcubane-carboxylic Acid. A solution of 1-bromo-4-(chloromethyl)pentacyclo[4.2.1.0^{2,5}.0^{3,7}.0^{4,8}]nonan-9-one ethylene ketal (1.3 g, 4.3 mmol) in HMPA (20 mL) was added dropwise to a solution of sodium borohydride (0.33 g, 8.6 mmol) in HMPA (20 mL) under a nitrogen atmosphere. The mixture was stirred overnight and then treated with water (100 mL) before being extracted with 1:1 ether/hexane (2 × 40 mL). The combined organic extracts were washed with water (3 × 30 mL) and then dried (MgSO₄). Evaporation of the solvent yielded 1-bromo-4-methylpentacyclo[4.2.1.0^{2,5}.0^{3,7}.0^{4,8}]nonan-9-one ethylene ketal (1.05 g, 91%), mp 81.5–82 °C (lit.²² mp 82–84 °C), which was used without further purification. The ketal (1.3 g, 4.8 mmol) was treated with 75% sulfuric acid (30 mL) as discussed by Edward and associates⁴³ to give 1-bromo-4-methylpentacyclo[4.2.1.0^{2,5}.0^{3,7}.0^{4,8}]nonan-9-one (0.8 g, 72%). Ring contraction was effected as described⁴³ and afforded 4-methylcubane-carboxylic acid (0.36 g, 46%); mp 143–144 °C (lit.⁴⁴ mp 139.5–141.0 °C).

4-Methylcubyl Bromide (9d). Bromodecarboxylation of 4-methylcubane-carboxylic acid (0.35 g, 2.2 mmol) was performed as described for the parent bromide.^{6b} Distillation (Kugelrohr) (90 °C (6 mmHg)) gave 4-methylcubyl bromide (**9d**) (0.33 g, 77%); mp 28–29 °C; ¹H NMR δ 1.29 (3 H, s), 3.74 (3 H, dd, *J* = 4.6, 5.7 Hz), 4.12 (3 H, dd, *J* = 5.7, 4.6 Hz); ¹³C NMR δ 19.12 (CH₃), 48.02 (C_{2,6,8}), 53.85 (C_{3,5,7}), 56.56 (C₄), 56.14 (C₁); EIMS *m/z* (relative intensity) 196, 198 (6), 156, 158 (17), 118 (20), 117 (82), 115 (100); HRMS calcd for C₉H₉⁷⁹Br 195.9888, found 195.9906.

Methyl 4-Bromocubane-carboxylate (9f). Treatment of 4-(methoxycarbonyl)cubane-carboxylic acid (1.7 g, 8.2 mmol) under Barton bromodecarboxylation conditions^{6b} afforded, upon sublimation (100 °C (0.05 mmHg)), methyl 4-bromocubane-carboxylate (1.6 g, 80%); mp 121 °C (lit.⁴⁴ mp 119–121 °C).

4-Chlorocubyl Bromide (9g). Methyl 4-bromocubane-carboxylate (**9f**) (1.12 g, 4.6 mmol) was treated with methanolic sodium hydroxide as outlined for the hydrolysis of the fluoro ester above. Extraction was effected with 1:1 ether/THF (3 × 30 mL) to afford the desired acid (1.0 g, 95%), mp 212 °C (lit.⁴⁴ mp 213.5–216.5 °C). The acid (1.0 g, 4.4 mmol) was converted into the corresponding acid chloride, which was dissolved in 1,1,1-trichloro-2,2,2-trifluoroethane (10 mL) and added dropwise under irradiation with light from a 300-W tungsten lamp to a stirred, boiling suspension of the sodium salt of *N*-hydroxypyridine-2-thione (0.72 g) and 4-(dimethylamino)pyridine (several milligrams) in 1,1,1-trichloro-2,2,2-trifluoroethane (20 mL). After 30 min the reaction mixture was cooled and washed successively with water (1 × 20 mL) and concentrated hydrochloric acid (3 × 20 mL). The organic layer was dried (MgSO₄/K₂CO₃) and the solvent evaporated. Sublimation of the residue (110 °C (6 mmHg)) gave 4-chlorocubyl bromide (**9g**) (0.58 g, 60%); mp 166–168 °C; ¹H NMR δ (CFCl₃) 4.22 (s); ¹³C NMR δ 72.81 (C₄), 63.65 (C₁), 54.01 (C_{2,6,8}), 52.76 (C_{3,5,7}); EIMS *m/z* (relative intensity) 156, 158 (4), 136 (6), 112 (12), 102 (100); HRMS calcd for C₈H₆³⁵Cl (M – Br) 137.0160, found 137.0160. Anal. Calcd for

C₈H₆BrCl: C, 44.2; H, 2.8. Found: C, 44.0; H, 2.6.

Methylcubane (18). A 1.7 M solution of *tert*-butyllithium in pentane (6.5 mL, 11.1 mmol) was added at –78 °C to a stirred solution of iodocubane (1.09 g, 4.4 mmol) in 1:1 ether/pentane (24 mL) while the temperature of the mixture was maintained below –70 °C. The temperature was held at –80 °C for an additional 10 min, and then the reaction was quenched by dropwise addition of methyl triflate (2.5 mL) such that the temperature did not exceed –60 °C. The reaction mixture was then allowed to warm to room temperature, after which it was washed successively with water (2 × 20 mL), dilute HCl (1 × 20 mL), and saturated NaHCO₃ (2 × 20 mL). The solution was dried (MgSO₄) and concentrated to about half its original volume by distillation through a column packed with glass helices before being stirred overnight with a saturated NaHCO₃ solution (10 mL). The organic layer was washed with water (20 mL) and dried (MgSO₄). Removal of the solvent via the packed column and distillation of the residue into a cold trap (–100 °C) afforded a product (0.40 g) shown (GC, ¹H and ¹³C NMR) to consist predominantly of methylcubane (**18**), which had spectroscopic properties in accord with reported data.⁴⁵

EPR Spectra. The bromocubane (ca. 5 mg) was dissolved in di-*tert*-butyl peroxide (ca. 30 μL) and triethylsilane (ca. 20 μL). This solution was placed in a quartz EPR tube and degassed on a vacuum line by a series of freeze–pump–thaw cycles. The solvent, e.g., cyclopropane or CCl₂F₂, was distilled in and the tube was sealed. Experiments were also carried out with hexamethylditin in place of triethylsilane, but no well-defined spectra were observed. In the hydrogen abstraction experiments samples were prepared in a similar way but without Et₃SiH or Me₃SnSnMe₃.

Photobromination of Cubane. Bromine (90.0 mg, 0.56 mmol) in CCl₄ (1 mL) was added to a solution of cubane (32.0 mg, 0.31 mmol) in degassed CCl₄ (2 mL) in an NMR tube. This was left in daylight for 24 h. The white solid, *cis,cis*-3,4,7,8-tetrabromo-*syn*-tricyclo[4.2.0.0^{2,5}]octane (**30**), that precipitated was filtered and recrystallized from methylene chloride (39.2 mg, 30%); mp 223–224 °C dec; ¹H NMR δ 3.44 (s, 4 H), 5.28 (s, 4 H); ¹³C NMR δ 47.62 (CH), 49.97 (CH); EIMS *m/z* (relative intensity) 266 (4), 264 (8), 262 (5), 185 (22), 184 (53), 183 (24), 182 (49), 169 (21), 104 (100), 103 (100), 78 (95), 77 (82), 69 (37), 52 (38), 51 (3), 50 (45). Anal. Calcd for C₈H₈Br₄: C, 22.7; H, 1.9. Found: C, 22.6; H, 2.1. The structure was confirmed by an X-ray diffraction study. The crystal was a colorless prism; data were collected with a Nonius CAD-4 diffractometer, using graphite-monochromated Mo K_α radiation, ω/2θ mode. A total of 2911 reflections were measured. The crystal was of poor quality and gave poor data (final *R* = 0.117), but fully confirmed the structure as shown in **30** (see the supplementary material). The supernatant liquid was examined by ¹H and ¹³C NMR, which showed cubane but no other significant products and, in particular, no bromocubane.

Photochlorination of Cubane. Chlorine gas was passed through CCl₄ (10 mL) at 0 °C for 1 h. The solution was allowed to attain room temperature. An aliquot was removed and found to be 2.3 M in chlorine by titration.⁴⁶ To cubane (50.0 mg) in an NMR tube was added dropwise the chlorine solution (0.4 mL, 2 equiv). A vigorous reaction ensued leaving a colorless solution. GC–MS analysis showed the solution to contain cubane (14%) and chlorocubane (28%) (identified by comparison of its MS data and retention time with those of an authentic specimen); EIMS *m/z* (relative intensity) [C₈H₇Cl]⁺ 140 (0.5), 138 (1.5), 114 (7), 112 (21), 103 (100), 77 (76). Two isomers of dichlorocubane were present (12% and 6%) (essentially identical MS): EIMS *m/z* (relative intensity) [C₈H₆Cl₂ – 1]⁺ 173 (0.3), 171 (0.4), 148 (6), 146 (8), 114 (5), 112 (17), 102 (100). A species tentatively assigned as **32** (2.3%): EIMS *m/z* (relative intensity) [C₈H₅Cl₃]⁺ 213 (6), 211 (24), 209 (22), 177 (10), 175 (63), 173 (100), 147 (52), 113 (94).

Acknowledgment. We thank Dr. M. R. Taylor (Flinders University) and Dr. A. H. White (University of Western Australia) for the crystal structure and the Science and Engineering Research Council and the Australian Research Council for financial support.

Supplementary Material Available: Displays of the EPR spectra of cubyl radicals (**10a–c,f**) and the 1-(diethylsilyl)ethyl radical (**19**) and the EPR spectrum of 4-chlorocubyl (**10g**) with simulations including and without the contribution from ³⁷Cl, together with the EPR spectrum of the cyclopropyl radical; a display of the EPR spectrum of 4-methylcubyl (**10d**) and its simulation, with

(43) Edward, J. T.; Farrell, P. G.; Langford, G. E. *J. Am. Chem. Soc.* **1976**, *98*, 3075–3085.

(44) Klunder, A. J. H.; Zwanenburg, B. *Tetrahedron* **1972**, *28*, 4131–4138.

(45) Della, E. W.; Pigou, P. E. *J. Am. Chem. Soc.* **1984**, *106*, 1085–1092.

(46) Taylor, N. W.; Hildebrand, J. H. *J. Am. Chem. Soc.* **1923**, *45*, 682–694.

the spectrum obtained on hydrogen abstraction from **18** and simulations with equal and statistical proportions of the three methylcubyl radicals; EPR spectrum of the tricyclo allyl radical **6**; a plot of the measured activation energies for β -scission of cyclo-

and polycycloalkylcarbinyl radicals against relief of ring strain Δ SE; and a listing of crystal and structural data for *cis,cis*-3,4,7,8-tetrabromo-*syn*-tricyclo[4.2.0.0^{2,5}]octane (**30**) (12 pages). Ordering information is given on any current masthead page.

An Axiomatic Model of the Intramolecular Diels–Alder Furan Reaction

Daniel P. Dolata^{*,†} and Laurence M. Harwood[‡]

Contribution from the Department of Chemistry, University of Arizona, Tucson, Arizona 85721, and Dyson Perrins Laboratory, University of Oxford, South Parks Road, Oxford OX1 3QY, U.K. Received May 26, 1992

Abstract: An axiomatic model has been created for the intramolecular Diels–Alder furan (IMDAF) reaction. The model is based on the energetics of implicit transition states, which are deduced from explicit starting material and product conformations. These explicit conformations are obtained by a combination of the WIZARD and MM2 programs. The model gives good quantitative agreement for 15 out of 16 IMDAF reactions and affords a good qualitative agreement for the remaining reaction. In several cases, the model was used to make predictions about as yet untried reactions, and in all but one case, the model was successful in predicting the results of the reactions. The technique of implicit transition-state modeling is not based on any specific characteristics of the IMDAF reaction and should provide a new and rapid method for modeling many classes of reactions.

Introduction

The intramolecular Diels–Alder (IMDA) reaction provides an excellent method for constructing complex ring systems with good stereocontrol.¹ However, the reaction is not as simple as it might appear at first glance.² In many cases, it is neither purely kinetically controlled nor thermodynamically controlled, although it is often reversible and is capable of giving a mixture of endo and exo products (the reactions of furans with dieneophiles, for instance). Intermolecular DA reactions of normal dienes generally occur under kinetic conditions and furnish the endo product. This has been explained by utilizing a mixture of frontier molecular orbital (FMO) theory and steric considerations.^{1b,3} FMO theory says that the transition state leading to the endo product gains increased stabilization due to favorable nonbonding orbital overlap, while steric considerations generally direct the exo product to be less sterically hindered and, therefore, more stable.

The analysis of intramolecular Diels–Alder reactions is more complex, since one has to take into account not only the relative stabilities of the endo and exo products and the stabilizing effect of FMO overlap on the transition state but also the ability of the connecting chain to fold into the required conformation found in the transition state, as shown in Figure 1 (based on a figure from Roush et al.).^{4a} Since the reaction is complicated, an exhaustive theoretical analysis of the intramolecular Diels–Alder reaction would require substantial effort. If the reaction went to thermodynamic equilibrium, all that a model would require would be the determination of the full ensemble of all product conformations, the calculation of their relative energies, and the utilization of the Boltzmann distribution to predict the product ratios. However, many (if not most) DA reactions are not run to strict thermodynamic completion in the laboratory. One example of this can be found in the studies of Roush.⁴ When Roush performed the intramolecular DA reactions at temperatures ranging from 150 to 180 °C for time periods ranging from 5 to 40 h in the absence of catalysts, he received *trans:cis* product ratios ranging from 60:40 to 72:28. When aluminum catalysts were used, the reactions proceeded easily near room temperature, thermodynamic

equilibrium was achieved, and the product ratios changed dramatically in all but one case. Other DA reactions have been reported to change their product ratios when performed under conditions of acid catalysis.^{2b} Partial or complete kinetic control of the Diels–Alder reaction is also found in Houk's studies of transition-state energies of the reactions of nonatriene and decatriene. Houk found a "qualitative agreement with experimental trends".⁴ Since product ratios are controlled by transition-state energies in kinetic reactions, this suggests a significant amount of kinetic control.

Recently one of us (L.M.H.) has been studying the intramolecular Diels–Alder furan reaction (IMDAF) as a means for the stereospecific construction of 7,6-fused carbobicycles with a view toward developing methodology for phorbol and daphnane syntheses.⁵ The reactions do not normally proceed at room pressure but can be accelerated by the application of high (5–19

(1) (a) Blokzijl, W.; Blandamer, M. J.; Engberts, J. B. F. N. *J. Am. Chem. Soc.* **1991**, *113*, 4241. (b) Breiger, G.; Bennet, J. N. *Chem. Rev.* **1980**, *80*, 63. (c) Jung, M. E.; Gervay, J. *J. Am. Chem. Soc.* **1991**, *113*, 224. (d) Keay, B. A.; Dibble, P. W. *Tetrahedron Lett.* **1989**, *30*, 1045. (e) Rogers, C.; Keay, B. *Tetrahedron Lett.* **1989**, *30*, 1349. (f) Keay, B. *J. Chem. Soc., Chem. Commun.* **1987**, 419. (g) Jung, M. E.; Truc, V. C. *Tetrahedron Lett.* **1989**, *29*, 6059. (h) Sauer, J.; Sustmann, R. *Angew. Chem., Int. Ed. Engl.* **1980**, *19*, 779. (i) Fallis, K. *Can. J. Chem.* **1984**, *62*, 183.

(2) (a) Jung, M. *Synlett* **1990**, 4, 186. (b) Rogers, C. *Synlett* **1991**, 5, 353. (c) Jung, M. E.; Gervay, J. *J. Am. Chem. Soc.* **1989**, *111*, 5469. (d) Jung, M. E.; Gervay, J. *Tetrahedron Lett.* **1988**, *29*, 2429. (e) Houk, K. N.; Paddon-Row, M. N.; Rondan, N. G.; Wu, Y.; Brown, F. K.; Spellmeyer, D. C.; Metz, J. T.; Li, Y.; Loncharich, R. *J. Science* **1986**, *231*, 1108. (f) Boeckman, R. K., Jr.; Ko, S. S. *J. Am. Chem. Soc.* **1980**, *102*, 7146. (g) White, J. D.; Sheldon, B. G. *J. Org. Chem.* **1981**, *46*, 2273. (h) Dewar, M. J. S.; Pierini, A. B. *J. Am. Chem. Soc.* **1984**, *106*, 209.

(3) Fukui, T. *Ang. Chem., Int. Ed. Engl.* **1982**, *21*, 801.

(4) (a) Roush, W. R.; Gillis, H. R.; Ko, A. I. *J. Am. Chem. Soc.* **1982**, *104*, 2269. (b) Brown, F. K.; Houk, K. N. *Tetrahedron Lett.* **1984**, *25*, 4609.

(5) (a) Harwood, L. M.; Iszhikawa, T.; Phillips, H.; Watkin, D. *J. Chem. Soc., Chem. Commun.* **1991**, 527. (b) Harwood, L. M.; Jackson, B.; Jones, G.; Prout, K.; Thomas, R.; Witt, F. *J. Chem. Soc., Chem. Commun.* **1990**, 609. (c) Harwood, L. M.; Jones, G.; Pickard, J.; Thomas, R. M.; Watkin, D. *J. Chem. Soc., Chem. Commun.* **1990**, 605. (d) Harwood, L. M.; Jones, G.; Pickard, J.; Thomas, R. M.; Watkin, D. *Tetrahedron Lett.* **1988**, 5825. (e) Harwood, L. M.; Leeming, S. A.; Isaacs, N. S.; Jones, G.; Pickard, J.; Thomas, R. M.; Watkin, D. *Tetrahedron Lett.* **1988**, 5017.

^{*} University of Arizona.

[†] University of Oxford.